



Handleiding

CAV filterkast/voorafscheider
CA F1, CA F2 en CA F3

MSH equipment
Appelmarkt 7
1681 PE Zwaagdijk-Oost
Tel: 0228-561100
Fax: 0228-561112
Mail: info@msh-equipment.nl

Website: www.msh-equipment.nl



CONTENTS

1 GENERAL INFORMATION	3	5.5 JOB END	15
1.1 MANUFACTURER	3	5.6 DECOMMISSIONING	15
1.2 POINTS OF SALE AND SERVICE CENTRES	3	6 MAINTENANCE	15
1.3 CERTIFICATES	3	6.1 MACHINE CUT-OFF	15
1.4 WARRANTY	3	6.2 SPECIAL PRECAUTIONS	15
1.5 CUSTOMER'S OBLIGATIONS	3	6.3 PARTS SUBJECT TO MAINTENANCE	16-17
1.6 MANUAL LAYOUT	4	6.4 CLEANING	18
1.6.1 PURPOSE AND CONTENTS	4	6.5 ROUTINE MAINTENANCE	18
1.6.2 MANUAL ADDRESSEES	4	6.6 EXTRAORDINARY MAINTENANCE	18
1.6.3 MANUAL STORAGE	4	7 DIAGNOSTICS	19
1.6.4 SYMBOLS	4	7.1 TROUBLESHOOTING	19
2 MACHINE DESCRIPTION	5	7.2 AFTER-SALES SERVICE	20
2.1 PRINCIPLE OF OPERATION	5	8 SPARE PARTS	20
2.2 MAIN COMPONENTS	5	8.1 SPARE PARTS LIST	20
2.3 MACHINE STRUCTURE	5	8.2 ORDERING SPARE PARTS	21
2.4 DIMENSIONS	5	9 SCRAPPING	21
2.5 AMBIENT CONDITIONS	5	9.1 DISPOSING OF WASTE	21
2.6 LIGHTING	5	9.2 MACHINE SCRAPPING	21
2.7 VIBRATIONS	5	10 ANNEXES	21
2.8 NOISE EMISSIONS	5	10.1 DECLARATIONS	29
2.9 SPECIFICATIONS	6	10.2 DIAGRAMS	22-28
2.10 OUTFIT	6	10.3 WARRANTY FORM	30
2.10.1 STANDARD	6	10.4 MAINTENANCE LOG BOOK	31
2.10.2 OPTION EQUIPMENT ON REQUEST	6		
2.11 ELECTROMAGNETIC ENVIRONMENT	6		
3 SAFETY RULES	7		
3.1 GENERAL WARNINGS	7		
3.2 INTENDED USE	7		
3.3 UNSUITABLE USE	7		
3.4 DANGEROUS AREAS	7		
3.5 SAFETY DEVICES	7		
3.6 STOP CONTROLS	8		
3.7 SAFE WORKING PROCEDURES	8		
3.8 RESIDUAL RISKS	8		
3.9 NAMEPLATES	8		
4 INSTALLATION	9		
4.1 TRANSPORT AND HANDLING	9		
4.2 STORAGE	9		
4.3 ARRANGEMENTS BEFORE INSTALLATION	9		
4.4 ASSEMBLY	10		
4.5 SET-UP	10		
4.6 CONNECTIONS	11		
4.6.1 PNEUMATIC CONNECTIONS	11		
4.6.2 ELECTRIC CONNECTIONS	12		
4.6.3 DUST INLET	13		
4.6.3a SUCTION INLET	13		
4.7 PRELIMINARY INSPECTION	13		
4.8 ADJUSTMENTS AND CHECKS	13		
5 OPERATION	14		
5.1 PERSONNEL	14		
5.2 CONTROL PANEL	14		
5.3 COMMISSIONING AND USE	14		
5.4 OPERATING MODES	15		



1 GENERAL INFORMATION

1.1 MANUFACTURER

CAV S.r.l. has been manufacturing Service control units for industrial use for more than twenty years; this experience has led to a considerable technological Know-how based on many years of R&D activities carried out in tight connection with the product manufacturing and trading on the international market, and this is the best quality guarantee that CAV can offer to users.

1.2 POINTS OF SALE AND SERVICE CENTRES

CAV directly offers after-sales service for its products sold in Italy or in Europe.
(Sales, After-sales, Spare parts)

CAV S.r.l.,
Via Morandi, 93 - Toscanella di Dozza (Bologna), Italy
Postal Code 40060
Phone +39 (0)542 673488
E-mail: sales@cavitaly.com

Customers are kindly requested to contact the above-indicated central After-sales Service for any doubt or clarification about use, maintenance or request for spare parts. Please remember to specify the Machine identification details that can be found on the nameplates:
See Nameplate A, paragraph 3.9

1.3 CERTIFICATION

The Machine complies with the prevailing European Union Directives applicable at the moment of its release on the market, as detailed in the declaration of conformity.

1.4 WARRANTY

Machine components are covered by a 12-month (twelve month) warranty: this period starts from the date indicated on the purchase document (invoice). **Warranty does not cover electrical and electronic parts.**

Warranty only covers faulty parts, no labour costs and service call fee.

Warranty excludes any Filtering unit damage due to:

- transport and/or handling;
- wrong or improper use of the Machine;
- failed compliance with maintenance specifications given in this Manual; (see paragraph 6.5)
- failures and/or faults not ascribable to faulty parts.

1.5 CUSTOMER'S OBLIGATIONS

The Customer shall, within the time frame agreed upon with the Manufacturer, fulfil its obligations indicated in the Documents attached to the sales contract. Unless otherwise agreed, the Customer normally shall take care of:

- Preparing the rooms, including any required building works and/or channels.
- Air supply with compressed air (see paragraph 4.6.1).
- Machine Power Supply, complying with the prevailing rules in the Country of use (see paragraph 4.6.2).



1.6 MANUAL LAYOUT

The Customer is required to carefully read this manual since correct pre-setting, installation and use of the Machine are basic requirements for its trouble-free and safe operation.

1.6. 1 PURPOSE AND CONTENTS

This manual shall give all necessary information for correct and safe use of the product. It deals with technical information, operation and maintenance details, as well as instructions for spare parts and safety warnings. Before attempting any operation on the machine, operators and qualified technicians are required to carefully read the instructions given herein.

Manual content derives from an ongoing and methodical job of data processing and technical tests filed and approved by C.A.V., complying with the internal safety procedures and data quality rules.

Data herein indicated are **EXCLUSIVELY** for specialised personnel, that could interface with the product under safety conditions for any person, the machine and the environment, carry out a simple troubleshooting and understand strange/faulty operating conditions, carry out simple inspections and maintenance, still fully complying with the instructions given in the following pages and prevailing health and safety regulations.

All details about installation, assembly, removal, extraordinary maintenance, repair and installation procedures for any accessories, devices and equipment, are mentioned and can only be performed by specialised personnel or by the **AUTHORISED AFTER-SALES CENTRE**, fully complying with the manufacturer's recommendations and the prevailing health and safety rules.

It is important to keep this manual in a known place and ensure it is legible, for possible future reference. In case of damage or for further technical and operation details, please contact directly our **AUTHORISED AFTER-SALES SERVICE**.





1. 6. 2 MANUAL ADDRESSEES

This Manual addresses both the operator and the technicians allowed to carry out maintenance operations on the machine. Operators shall not carry out any operation reserved to Maintainers or Qualified Technicians. Failure to do so, the Manufacturer will not be liable for any resulting damage.

1.6.3 MANUAL STORAGE

This Manual shall be kept next to the Machine and in such a position protected from any fluid or any other condition that could compromise its readability.

1.6.4 SYMBOLS

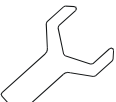
	DANGER	Indicates a hazard resulting in a (serious) risk for user or any other person.
	WARNING	Pay utmost attention to the paragraphs highlighted by this symbol.
	DANGER OF ELECTROCUTION	Indicates a hazard of electrocution resulting in a (serious) risk for user or any other person.
	SPECIALISED PERSONNEL	Specialised personnel is required for special operations.
	SEE MANUAL	It is necessary to refer to the User's Manual before attempting a certain operation.
	ADJUST	Mechanical adjustment and/or electric set-up could be necessary.



2 MACHINE DESCRIPTION

2.1 PRINCIPLE OF OPERATION

This CAV filtering unit is made of a load bearing frame on which are installed mechanical, electromechanical, electronic and pneumatic devices or units that are used, altogether or combined with one another, for filtering non-explosive dust.

The machine description specifies the intended use for which the product was designed, produced and protected. Any different use or failure to comply with the following specifications could create danger for persons and/or property.

The model described herein consists of some main and auxiliary units, whose functions are listed here below and are aimed at carrying out a production cycle under safety conditions.

Please exclusively contact directly the AUTHORISED AFTER-SALES SERVICE for further details or specifications.

2.2 MAIN COMPONENTS

The machine consists of the following main components:

1. Filter holder cylinder
2. Dust collector cylinder

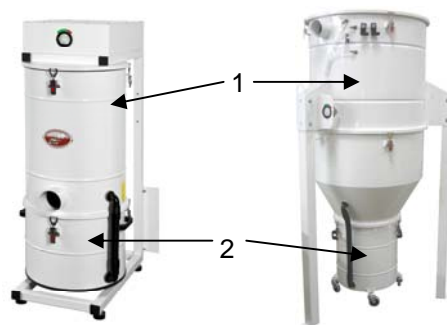

2.3 FILTERING UNIT STRUCTURE

Unit bedplate and main parts are made of a stiff metal structure. At the bottom is the dust collector bin. Power supply connections are realised by means of power and control cables.

2.4 DIMENSIONS

Overall dimensions are specified under paragraph 2.9 -Specifications.

2.5 AMBIENT CONDITIONS

The Filtering unit does not require any special ambient conditions. Nevertheless, it shall be installed in a well-lit industrial building, featuring suitable minimum guaranteed air change.

Ambient temperature for correct unit operation shall be in the range +5°C to +40° C.

2.6 LIGHTING

Room lighting shall comply with the prevailing rules in the country where the machine is installed. In the area where the Filtering unit is installed, good visibility shall be ensured for easier routine and extraordinary maintenance. Minimum recommended illumination: 400 lux.

2.7 VIBRATIONS

If unit is used according to the instructions for correct use, vibrations shall not create any dangerous situation.

2.8 NOISE EMISSIONS

The Filtering unit is designed and manufactured to limit noise emissions at the source.

Actual noise emission shall be measured after installation, in order to ensure that it still conforms to the specifications required by the prevailing laws.



2.9 SPECIFICATIONS

This section indicates Machine technical features and specifications user shall refer to in case of contact with the Manufacturer After-sales Service.

TABLE 2. 9A - Technical Features and Specifications

Description	Features
Power supply	230V-50Hz
Compressed air supply	Max 10 Bar
Max. air flow rate	F1: 700 cu. m/h F2: 1400 cu. m/h F3: 2100 cu. m/h
Relative humidity	Max 90% w/out condensate
Weight (kg)	F1: 55 kg F2: 130 kg F3: 135 kg
Dimensions	F1: 560x700x h1340 mm F2-F3: 1300x1300x h2400 mm

2.10 OUTFIT

The following equipment refers to the standard production Filtering units. Any special machine could hence require parts different than the listed ones.

2.10.1 STANDARD

The Filtering unit comes with:

- User's Manual
- Declaration of conformity
- Installation equipment

2. 10.2 OPTION EQUIPMENT ON REQUEST

No options are set with respect to the standard outfit.

Any change and/or addition of any accessory whatsoever must be explicitly approved and made by the Manufacturer.

2. 11 ELECTROMAGNETIC ENVIRONMENT

The Filtering unit is designed to operate correctly within an electromagnetic or industrial environment. Design conforms to the principles of the product Harmonised Technical Standards:

HARMONISED EUROPEAN STANDARD

EN 60439-1(third edition)

February (1995) ref. CENELEC EN 60439-1:1994-01

HARMONISED EUROPEAN STANDARD

EN 60439-1/AI/Ali September (1997) ref. CENELEC EN 60439-1/AI:1995-12+ EN 60439-1/AII:1996-02

In particular, manufacturer used proven components and principles, as required by 7.10 of EN 60439-1/ AI:1995-12+ EN 60439-1/AII:1996-02

Built-in electronic equipment was installed as indicated in the instructions that come with the equipment itself and considering the general criteria for **EMC** specified in **EN 60204-1 art. 4.**

HARMONISED EUROPEAN STANDARD EN 60439-1(third edition)

February (1995) ref. CENELEC EN 60439-1:1994-01

HARMONISED EUROPEAN STANDARD EN 60439-1/AI/Ali

September (1997) ref. CENELEC EN 60439-1/AI:1995-12+ EN 60439-1/AII:1996-02

In particular, manufacturer used proven components and principles, as required by 7.10 of EN 60439-1/ AI:1995-12+ EN 60439-1/AII:1996-02

Built-in electronic equipment was installed as indicated in the instructions that come with the equipment itself and considering the general criteria for **EMC** specified in **EN 60204-1 art. 4.**



3 SAFETY RULES

3.1 GENERAL WARNINGS

The Operator shall carefully read the information given in this Manual, especially the Safety rules and precautions specified in this section.

Moreover, it is fundamental that the Operator follows these warnings:

- Keep the Filtering unit and the work area clean and in order;
- Use the Filtering unit in normal psychophysical conditions;
- Wear appropriate clothes and personal protection gear suitable for products in use;
- Do not remove or tamper with the Manufacturer nameplates on Filtering unit;
- Do not remove or make inoperative any of the Filtering unit Safety systems.
- **Do not use this unit in rooms subjected to risk of explosion.**

3.2 INTENDED USE

The Filtering unit is designed for removing non-explosive dust in general or similar material.

3.3 UNSUITABLE USE

Do not use the Filtering unit:

- for different purposes than those indicated in 3.2;
- to take in substances that could result in a flammable and/or explosive environment;
- in environments featuring explosive, aggressive atmosphere or with high dust or oily content;
- in environments with a serious fire hazard;
- outdoors, exposed to any weather condition;
- to take in red-hot parts and/or parts on fire;
- in a different way than stated in safety installation rules given herein.

3.4 DANGEROUS AREAS

Although the Filtering unit does not involve any particular danger for exposed persons, it shall be used taking some precautions, considering that:

- the operator can come into contact with dangerous chemical products by accident and without being aware of the resulting danger.
- Before use, the person in charge of production shall evaluate unit use conditions according to the danger possibly caused by products and take suitable protections such as: work in a room featuring a guaranteed minimum ventilation or change of air.
- **Pay utmost attention when removing the dust bag. Carefully follow the filter removal procedure described in the manual.**

3.5 SAFETY DEVICES

The Filtering unit comes complete with suitable guards to protect the persons exposed to risks due to moving organs, pressurised air lines blowing up, or risks connected to power supply, and so on.

The unit fits the following safety devices:

- Safety release on the levers for removing the dust collector cylinder metal body.

The User is requested to install the following safety devices:

- **Electrical equipment with TT system:** automatic circuit breaker with differential protection against direct and indirect contacts on machine power control panel (if activated, it causes uncontrolled stop of all actuators and power cut-off);
- **Electrical equipment with TN or IT system:** refer to control panel specifications to install the suitable protections.



3.6 STOP CONTROLS

The Filtering unit stop controls are:

- main power cut-out by Main Switch (to set unit out of service located on control panel installed by the Customer);
- Cut-out through power plug.

3.7 SAFE WORKING PROCEDURES

The Filtering unit design features aim at eliminating all risks connected to its use.

The residual risks involved in operating mode are:

- risks connected with the use of pneumatic energy;
- risks connected with the use of electric energy;
- risks of possible contact with product removed by suction;

To limit the consequences of such dangers as much as possible, it is important to comply with the following rules:

- Ensure that air supply pressure is set to specified value: max. 10 bars;
- Do not start the Filtering unit before checking the correct installation and set parameters; this can be done by running a cycle with no product to be taken in by exhauster;
- Wear the personal protection gear suitable for the product in use;
- Wear clothes with close-fitting sleeves.

3.8 RESIDUAL RISKS

During the normal suction cycle and during maintenance, the Operators can run some residual risks that can not be completely avoided, due to the type of operation being performed, such as danger of electrocution.

3.9 NAMEPLATES

Table 3. 9A - Types of Nameplates

Nameplates on the Filtering unit fig.3.9.A









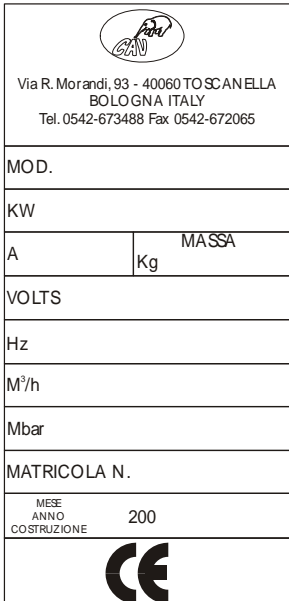

Nameplate "A"	Nameplate "B"	Nameplate "C"	Nameplate "D"																						
 <table border="1" style="width: 100%; border-collapse: collapse;"> <tr> <td colspan="2" style="text-align: center;">  Via R. Morandi, 93 - 40060 TO SCANELLA BOLOGNA ITALY Tel. 0542-673488 Fax 0542-672065 </td> </tr> <tr> <td colspan="2">MOD.</td> </tr> <tr> <td colspan="2">KW</td> </tr> <tr> <td style="width: 50%;">A</td> <td style="width: 50%;">MASSA Kg</td> </tr> <tr> <td colspan="2">VOLTS</td> </tr> <tr> <td colspan="2">Hz</td> </tr> <tr> <td colspan="2">M³/h</td> </tr> <tr> <td colspan="2">Mbar</td> </tr> <tr> <td colspan="2">MATRICOLA N.</td> </tr> <tr> <td style="width: 50%;">MISE ANNO COSTRUZIONE</td> <td style="width: 50%;">200</td> </tr> <tr> <td colspan="2" style="text-align: center;">  </td> </tr> </table>	 Via R. Morandi, 93 - 40060 TO SCANELLA BOLOGNA ITALY Tel. 0542-673488 Fax 0542-672065		MOD.		KW		A	MASSA Kg	VOLTS		Hz		M³/h		Mbar		MATRICOLA N.		MISE ANNO COSTRUZIONE	200					
 Via R. Morandi, 93 - 40060 TO SCANELLA BOLOGNA ITALY Tel. 0542-673488 Fax 0542-672065																									
MOD.																									
KW																									
A	MASSA Kg																								
VOLTS																									
Hz																									
M³/h																									
Mbar																									
MATRICOLA N.																									
MISE ANNO COSTRUZIONE	200																								
																									
																									



Figure 3. 9 B - Nameplates position

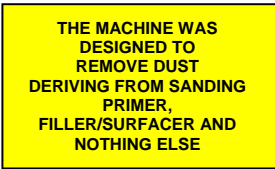

	WARNING! THE SAFETY WARNING NAMEPLATES SHALL NOT BE REMOVED, COVERED OR DAMAGED.
--	--

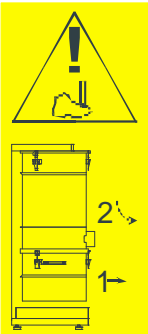
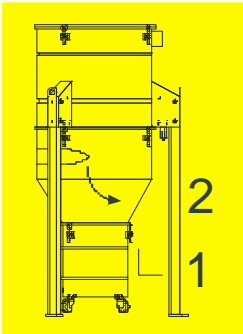
4 INSTALLATION

4.1 TRANSPORT AND HANDLING

Have unit transported by qualified and trained Personnel. The Filtering unit shall be handled in a suitable way so as to avoid damages. All protections, electric circuits, control equipment, shall be suitably closed and fastened.

The Filtering unit is packed on pallet, wrapped in plastic and covered with cardboard. Packed machine dimensions and weight are indicated on the package. Check for transport damages together with the carrier.

N.B.: The Manufacturer will not be liable for damages due to improper lifting and handling of the packed unit.

	WARRANTY does not cover any damage to the Filtering unit due to Transport and Handling. Any repair or replacement of damaged parts is at the Customer's charge.
--	--

4.2 STORAGE

For any long period of inactivity, store the Filtering unit in a suitable place, considering storage environment and time. In particular, consider allowed temperature range, humidity and pollution.

- Store the Filtering unit indoors;
- Protect the Filtering unit from any shock and stress;
- Protect the Filtering unit from humidity and extremely wide temperature ranges +0° C + 60 °C;
- Avoid contact with corrosive substances.

4.3 ARRANGEMENTS BEFORE INSTALLATION

Before installation, it is necessary to prepare a suitable operating area, limiting any interference with other activities as much as possible.



4.4 ASSEMBLY

Filtering unit can be assembled either by the Technicians authorised by the manufacturer or directly by the customer, following these steps:

Unpacking.

Remove all packing material from the machine, using suitable tools and setting it in a suitable place. Dispose of the packing material according to the prevailing environment protection regulations.

(Visually) **check** machine external parts for damage, carefully ensure that there are no scratches, denting or damaged parts.

Report any fault, failure or missing parts found within five days from machine arrival. Beyond this term the Manufacturer is no longer liable for the machine supplied.

WARNINGS AND PRECAUTIONS for installation

Always start by checking correct operation, assembly and efficiency of controls and safety systems. **In case** you find operating faults, immediately stop the machine and contact the AUTHORISED AFTER-SALES SERVICE. **Pay attention** to the adhesive nameplates on the machine. Should they become damaged or illegible, promptly change them. For this operation contact the AUTHORISED AFTER-SALES SERVICE or the Manufacturer. Have **any maintenance intervention** -as per the definition of "user" given in the foreword section- performed by qualified personnel. **Using spare parts** that do not comply with the following specifications, any change or tampering (though small as they may be) relieve the Manufacturer of any liability concerning the correct use, operation and safety of persons and/or property. **It is strictly forbidden** to tamper with equipment, control organs and safety devices. **Dispose of waste** as required by the prevailing laws. **If the machine is used by many operators**, all of them shall read the instructions for use and indicate any maintenance intervention or parts replaced, or just suspected faults on the servicing data sheet.

4.5 SET-UP

Set the Filtering unit on a flat and clean surface and ensure that the equipment and tools for machine mechanical set-up are in place.

Once the machine has been positioned, level it and fix it to the wall/floor by means of special holes on the side brackets for F1 and on the cylinder supports lower side for F2/F3.

N.B.: It shall always be possible to work all around the machine for maintenance purposes. Ensure there is enough room in this area upon installation.

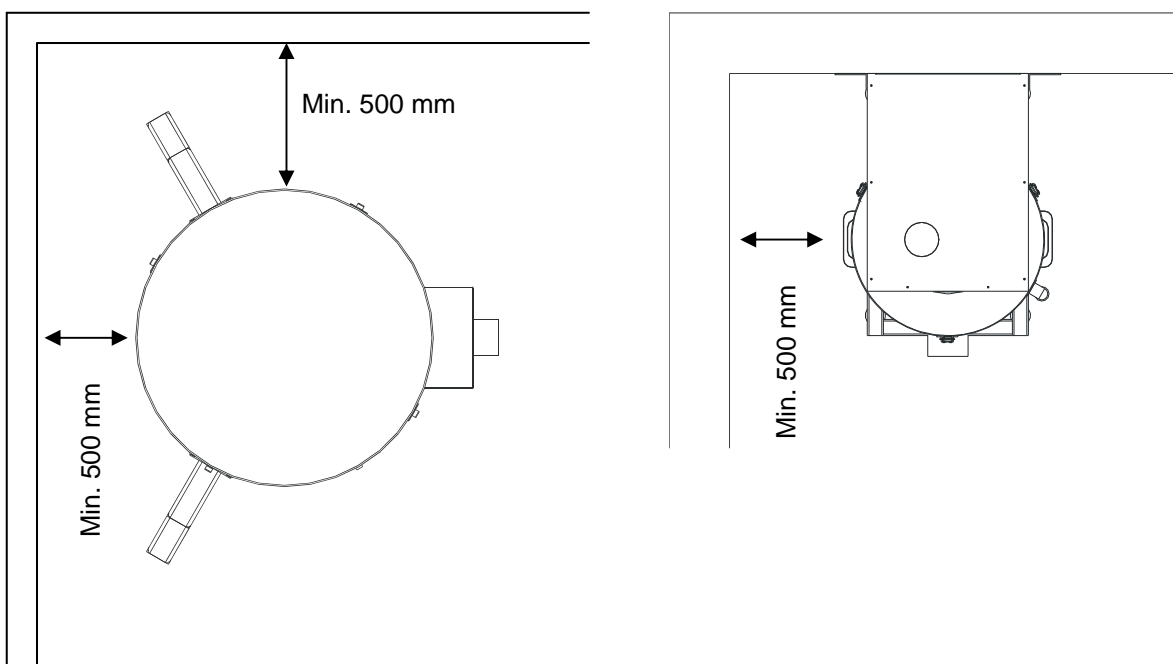

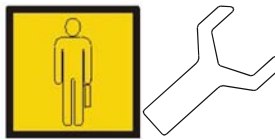

4.6 CONNECTIONS

To avoid any problem at Filtering unit start-up, follow the instructions below.

4.6.1 PNEUMATIC CONNECTIONS

Figure 4. 6. 1A- Pneumatic System Layout

Connection to the air supply is ensured by a hose connected to regulator filter (A).

The mobile connection is supplied together with the Filtering unit.

The standard filtering unit is provided with a filter-regulator unit (F2-F3) or regulator (F1).

Air supply requirements:

- Operating pressure: 5 bars
- Maximum pressure: 10 bars

Connect compressed air supply to the supplied tube, by inserting a gate valve (to be supplied by Customer) on the pre-set line so that the supply can be cut off during maintenance. It is strongly recommended to feed the machine with dry compressed air.

Compressed air of the supply line must be completely dry, i.e. treated upstream of the exhauster. It is recommended to install a 5 micron air filter.

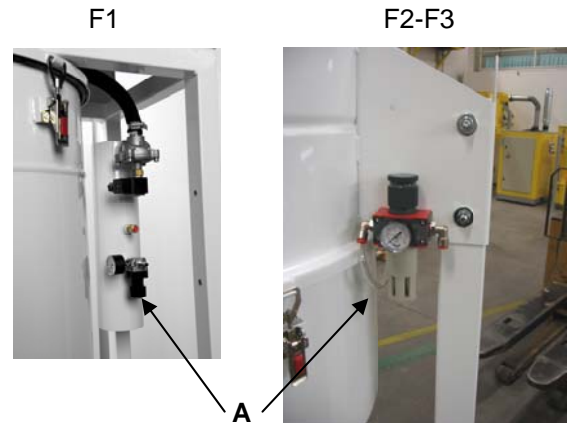



4.6.2 ELECTRIC CONNECTIONS

Figure 4. 6. 3A- Electric System Layout

POWER SUPPLY

Filtering unit electrical connections are at the Customer's charge, under its own responsibility.

The electrical connections of the Filtering unit shall consider:

- the Laws and Technical standards applicable at the time of installation in the place of installation;
- data indicated on " Nameplate A ".

Make the electrical connections. Supply power to the machine with a separate line of suitable cross-section, also providing suitable protections for direct and indirect contact. **This line and the relevant protections are at the Customer's charge.**

- Power supply is provided with double insulation cable of suitable cross-section (approx. 3 m long) completed with power plug.
- Solenoid valves control cables with 2x1.5 sq. mm cross-section (approx. 3 m long) to be connected to the solenoid valves coils.

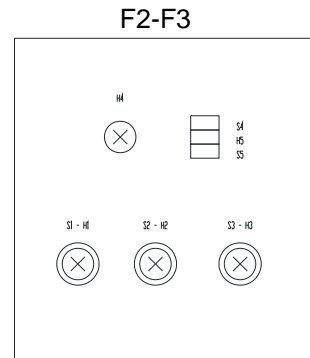
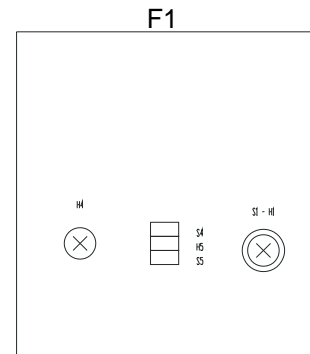

The electrical system design and components ensure utmost dependability and safety of use. The attached wiring diagrams will allow identification of all connections and components. Only make the required electrical connections; do not modify any circuits, calibrations, components, etc. Failure to follow this warning will be considered as tampering. Before connecting to the mains, ensure that power voltage and frequency correspond to the specifications indicated on the nameplate. **Perform ground connections and/or zero setting as required by the prevailing laws of the country.**



4.6.3 DUST INLET

It is necessary to connect the fitting placed on the dust cylinder (A) with 100 mm diameter by means of an antistatic hose coming from the suction main line. "Peel" the copper wire and fold it inward (if tube is grounded) or connect it to a ground or bonding lead. Fasten the hose with its metal clamp.

4.6.3a SUCTION INLET

It is necessary to connect the fitting placed on the filter holder cylinder (B) with 100 mm or 80 mm diameter respectively for F2-F3 and F1 by means of an antistatic hose deriving from the suction unit. "Peel" the copper wire and fold it inward (if tube is grounded) or connect it to a ground or bonding lead. Fasten the hose with its metal clamp.

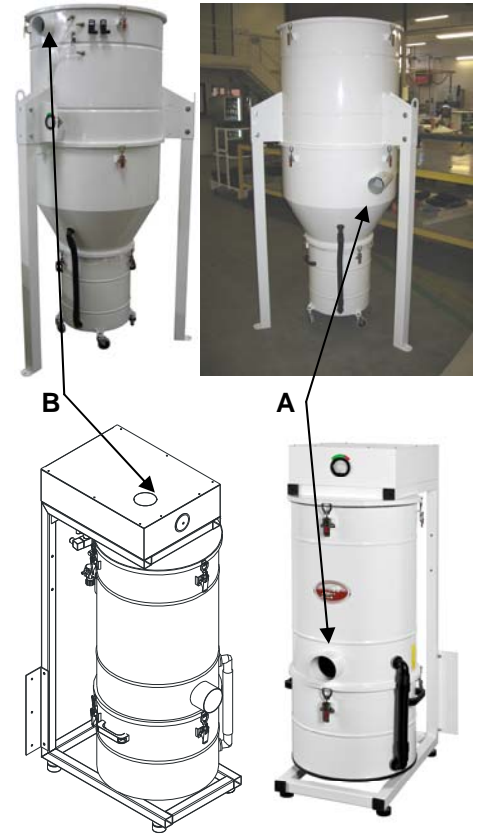

4.7 PRELIMINARY INSPECTION

Power supply, compressed air supply and Filtering unit preparation stages for Commissioning do not require any special knowledge apart from those acquired after reading this manual. Before starting up the Machine it is necessary to perform some inspections and checks in order to avoid errors or accidents:

- Ensure that the Filtering unit did not suffer any damage during assembly;
- pay special attention when checking electrical parts, control panels, cables and air lines;
- check that all external supplies connections are correct;
- Ensure that all mobile parts can move freely.

4.8 ADJUSTMENTS AND CHECKS

The Filtering unit is tested at the Manufacturer's premises, before shipment. No further adjustment is necessary.

When starting the filtering unit for the first time, proceed as follows:

- set the Main switch QSI lever to ON (**switch is installed by the Customer**);
- Press pushbutton "1" on control panel;
- open compressed air supply cock; ensure that compressed air regulator reads 5 bars;
- After being supplied, the Filtering unit sets to automatic operation mode.
- To change the cleaning and break time activate the trimmers according to the following scheme:
 - A: break time between two cleanings (0-2 minutes);
 - B: working time (0-2 seconds cleaning);
 - C: post-cleaning time (0-3 minutes).

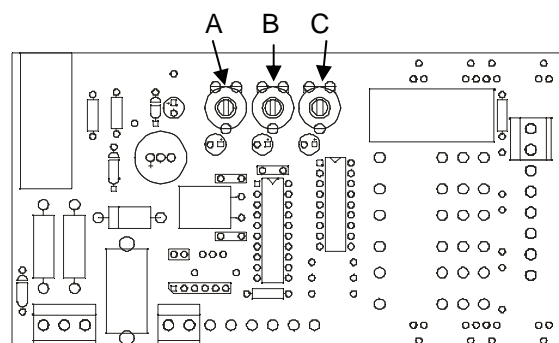



5 OPERATION

5.1 PERSONNEL

The Filtering unit is designed for use by many Operators.

Personnel allowed to work on the Filtering unit shall have the following knowledge (or acquire it after suitable training) and be familiar with the contents of this Manual as well as all Safety-related concerns:

- General and technical knowledge of suitable level to understand Manual contents;
- Knowledge of the main health and safety and accident prevention rules;
- Knowledge of how to behave in an emergency situation, where to find personal protection gear and how to use it correctly.

Maintainers, apart from the above, shall also have suitable electrical, pneumatic and mechanical Technical knowledge.

5.2 CONTROL PANEL

Filtering unit controls are on the control panel.

Figure 5.2 a - controls on front panel

KEY:

1. Power on warning light
2. Starting pushbuttons
3. Manual filter cleaning luminous push-buttons (only two on F2 filtering unit and only one on the F1 filtering unit).

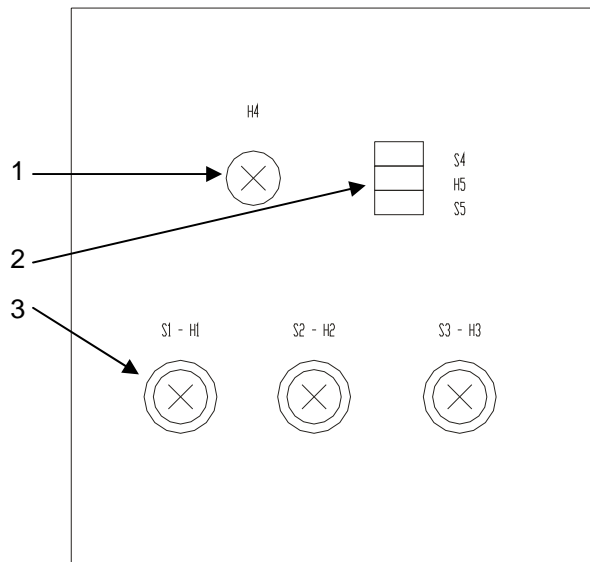

5.3 COMMISSIONING AND USE

To power on the Filtering unit proceed as follows:

1. set the Main Switch to ON
2. Open compressed air supply cock
3. When pushbutton "1" is activated, the machine starts and performs set function.



5.4 OPERATING MODES

After commissioning you can use the machine, no operator intervention is necessary.

5.5 JOB END

The procedure for a voluntary stop is as follows:

1. Turn the main switch on the electric panel installed by the customer to OFF or disconnect the power plug;
2. Close compressed air supply cock.

5.6 DECOMMISSIONING

In case of long periods of inactivity or **in case of maintenance, user shall compulsorily:**

- Open and padlock the main switch on main control panel (see Figure 6.1 A);
- Close and lock compressed air inlet valve (see Figure 6.1.B);
- Release circuit air by opening the condensate drain cock;
- Put out a panel reading "FILTERING UNIT BEING SERVICED".

6 MAINTENANCE

6.1 FILTERING UNIT CUT-OFF

Before attempting any Maintenance or Repair job, user must cut all Filtering unit supplies, proceeding as follows:

1. Turn the switch on the main electric panel to OFF and padlock it, and remove the power plug from the relevant outlet.
2. Close and padlock the compressed air supply and open the condensate drain cock to drain the system.

6.1A

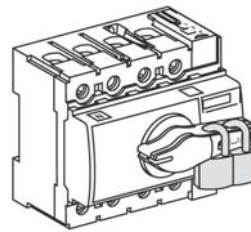

6.1B

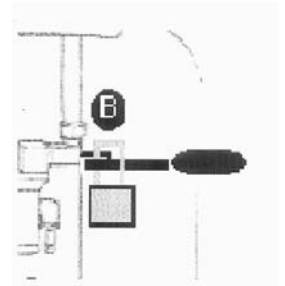

6.2 SPECIAL PRECAUTIONS

When carrying out maintenance or repair jobs, it is recommended to proceed as follows:

- Before starting, put out a panel reading "FILTERING UNIT BEING SERVICED" in a visible position.
- Do not use solvents and flammable materials;
- Do not release lubricants into the environment;
- Machine parts are not designed to bear a person's weight; do not stand on them or they could break.
- When job is completed, restore and correctly fasten all protections and guards previously removed or opened, as well as any safety device, if previously disabled.



6.3 PARTS SUBJECT TO ROUTINE MAINTENANCE

Maintenance shall be carried out with the Filtering unit set out of service for replacement of damaged or worn parts. The Filtering unit does not require frequent maintenance. If compressed air does not meet indicated requirements, the following could get damaged:

1. Pressure regulator
2. Solenoid valve
3. Filter cartridge
4. Dedusting device

1) Pressure regulator

Remove the regulator (F1):

- close air feed;
- Discharge any residual air;
- Reset the regulator by working the knob anticlockwise until it stops, then disconnect all the tubes connected to the regulator;
- Remove the regulator from the tank;
- Open the regulator by loosening the 4 M4 cross-headed screws;
- Clean or change the membrane then reassemble the unit proceeding in the reverse order.

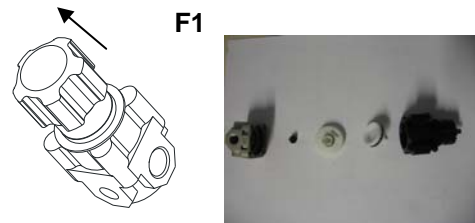
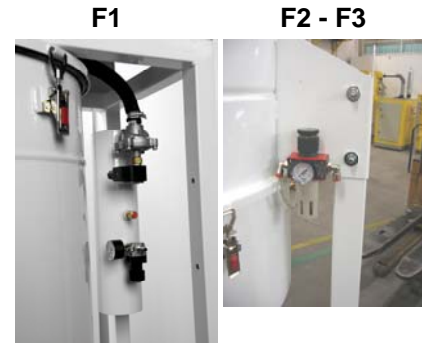

Remove the regulator (F2-F3):

- close air feed;
- Discharge any residual air;
- Reset (zero) the regulator by working the knob anticlockwise until it stops.
- Remove the adjuster knob by pulling it;
- Open the regulator by loosening the knob tang.
- Clean or change the membrane then reassemble the unit proceeding in the reverse order.

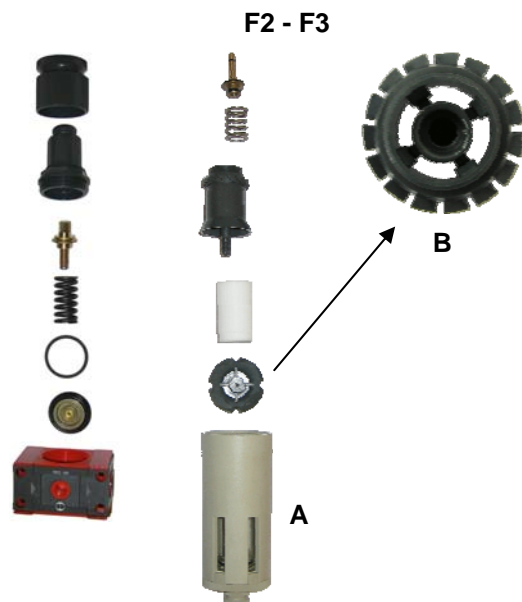

Shutter (only F2-F3)

- close air feed;
- Discharge any residual air;
- Reset (zero) the regulator by working the knob anticlockwise until it stops;
- Loosen filter-governor cup;
- Loosen filter bottom (A) and remove the filtering element;
- Loosen shutter seat and check for wear or damage (B).
- If necessary, change the shutter seat and reassemble proceeding in the reverse order.

2) Replace solenoid valve (B) if it jams. Change as follows:

- close air feed;
- release any residual air by opening the condensate drain cock;
- remove the connector by undoing the retaining screw;
- Remove the connecting tube and loosen the solenoid valve;
- clean and/or change the solenoid valve;
- Connect the connector, reconnect the lines, etc.

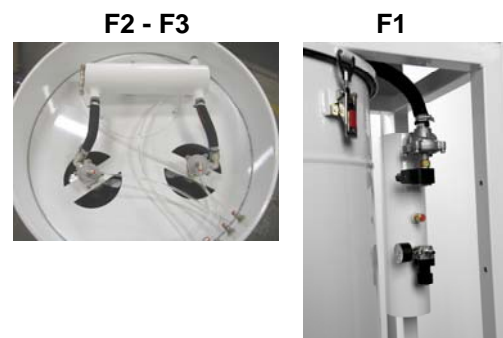



3) Filter cartridge

- Cut off power and air supply (see relevant procedures in the previous pages);
- Disconnect Ø100 inlet hose from inlet manifold;
- Remove the dust collector cylinder;
- Loosen nut under cartridge;
- set the new cartridge in place, ensuring to set it at the centre and that the seal correctly sets against the plate;
- tighten the nut, do not squeeze seal too much (nut finger tight + two turns);
- refit the dust collector cylinder;
- Refit the vacuum connection line between cylinders.
- Reconnect the Ø100 hose.

4) Dedusting device

- Cut off power and air supply (see relevant procedures in the previous pages);
- Proceed as described in step 4 until removing the filtering cartridge;
- Loosen the dedusting device and renew it;
- Reassemble as indicated in item 5.

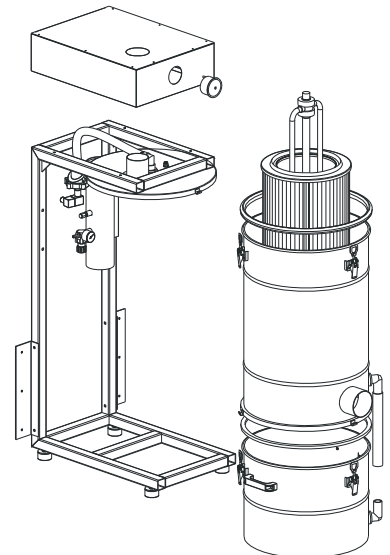
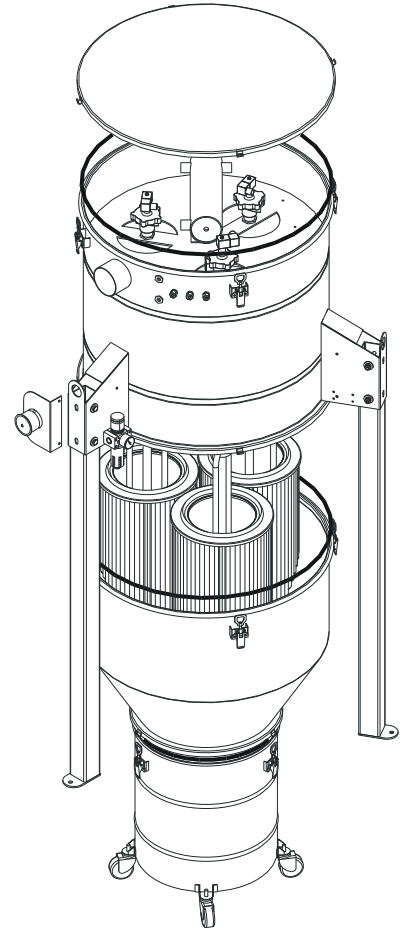



6.4 CLEANING

It is recommended to frequently clean the whole Machine (intervals depend on type and frequency of use). Use a soft rag. Do not use water and/or solvents.

- Changing the bag.** It is impossible to set a standard interval for replacing the dust collector bag so it is important to frequently check dust quantity during the first two weeks of use. Periodically empty the bag according to the work you do. Release the three levers to unlock the dust collector cylinder. Disconnect the vacuum tube and remove the cylinder by pulling the two side handles. Pull out the nylon bag and close it. Fit a new bag, ensure it adheres to cylinder walls. Turn over bag exceeding length on cylinder edge. Refit the dust collector cylinder and engage the three levers. **Important!** Refit and ensure that the vacuum tube does not leak. Any leak (though small as it may be) will move the nylon bag up toward the filter cartridge, thus blocking off the machine suction opening, and finally break the bag. It is necessary to dispose of the collected dust according to the prevailing laws of the country where machine is installed.



6.5 ROUTINE MAINTENANCE

The following operations shall be performed at the indicated time intervals. Failure to comply with this schedule will relieve the Manufacturer of any liability or warranty obligation.

These operations, though simple as they may be, shall be carried out by **suitably trained and expert Personnel**.

Scheduled routine maintenance includes inspections, tests and interventions aiming at preventing system stoppage due to faults or potentially dangerous situations.

6.6 EXTRAORDINARY MAINTENANCE

Extraordinary maintenance is an activity reserved to personnel appointed by the manufacturer or the manufacturer itself. Please contact the centres specified under paragraph 1.2 in case of need. **Considering the machine routine maintenance, the intervention of a technician for extraordinary maintenance is highly unlikely, unless for special cases or when expressly requested.**

MAINTENANCE	DESCRIPTION	INTERVENTION
Pneumatic System	Valves and tubes/lines	No scheduled maintenance required.
Electrical System	Control Panel	No scheduled maintenance required.
Suction System	Filter	Change every 2000 hours or when the load loss is more than 70/80 mm H ₂ O.
Dust collector bags	Change.	When necessary.
Electrical parts	Control panel internal parts	Maintenance-free. If they are faulty, have them changed by qualified personnel.



7 DIAGNOSTICS

7.1 TROUBLESHOOTING

Table 7.1 A

TROUBLE	CAUSE	INSPECTION AND/OR FIX
Dust is coming out of the suction unit.	<ul style="list-style-type: none"> Faulty filter cartridge Worn seal 	<ul style="list-style-type: none"> Change filter cartridge Change filter cartridge
The solenoid valve or regulator "hiss"	<ul style="list-style-type: none"> Poor air quality, dirty membranes Membrane failure 	<ul style="list-style-type: none"> Install air filter at inlet Clean/change regulator/solenoid valve
Filter is not automatically cleaned	<ul style="list-style-type: none"> No compressed air feed Dedusting device is stuck Faulty timer Faulty solenoid valve 	<ul style="list-style-type: none"> Restore compressed air feed. Clean/change dedusting device Replace the timer Clean/change the solenoid valve
Faulty or insufficient suction	<ul style="list-style-type: none"> Filter clogged due to failure of emptying dust collector bag Damp filter Suction of objects Dedusting device is stuck Faulty solenoid valve Faulty timer No compressed air feed 	<ul style="list-style-type: none"> Empty dust collector bag more frequently, an excessive quantity of accumulated dust clogs the filter cartridge Check for condensate in the machine accumulation tank. Install a filter at machine inlet Check for the correct suction value, disconnect tube diam.100 from dust cylinder. If suction is correct, system took in something that jams air passage in tube. Remove jamming. See above
Control electric panel does not switch on, even though it is correctly powered.	<ul style="list-style-type: none"> Mains fuse failure 	<ul style="list-style-type: none"> Check connection and change the fuse with one having the same rating
With openings open, differential pressure gauge displayed pressure is considerably different from zero	<ul style="list-style-type: none"> Clogged filter Clogged/broken connecting tubes Broken pressure gauge 	<ul style="list-style-type: none"> See above Clean the connecting tubes and reconnect them to pressure gauge Renew the pressure gauge

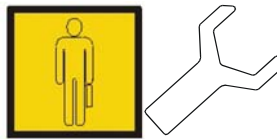

7.2 AFTER-SALES SERVICE

The Manufacturer is always willing to answer Customer's questions and give information on use, maintenance or installation and so on. Please follow the instructions given under paragraph 1.2 on how to request our assistance.

8 SPARE PARTS

8.1 SPARE PARTS LIST

Filtering unit use does involve some expendable parts. Following is the list of available spare parts and expendable parts.

Table 8.1- A

POS.	DESCRIPTION	PART NO.
1	Solenoid valve	A: 9018 B: 9029
2	Pressure regulator	F1: PCX-0001 F2-F3: 6709
3	Pressure gauge	K2-78
4	Dedusting device	K5-0080
5	Filter cartridge	K5-38-C-Alum.
6	Top seal	F1: 7860-0134 F2-F3: 7867
7	Bottom seal	7867
8	Differential pressure gauge	8153
9	Dust collection bag	99987



8.2 ORDERING SPARE PARTS

We remind you that the machine can only be repaired by a qualified technician.

It is hence recommended to contact the Manufacturer After-sales Service that will make available Qualified Personnel, suitable equipment and original spare parts.

To order above-listed spare parts, please refer to paragraph 1. 2

9 SCRAPPING

9.1 DISPOSING OF WASTE

During processing, waste or rejections are created that shall be collected, recycled or disposed of, in compliance with the prevailing laws of the country where the Machine is installed.

9.2 MACHINE SCRAPPING

Upon unit scrapping, separate the plastic parts from any electrical components, that shall be sent to different waste disposal centres, as per prevailing rules.

The machine metal parts shall be divided into steel and other metals or alloys, and then routed to recycling firms.

Unit scrapping does not cause any special risk, as far as it is performed by qualified personnel with suitable equipment.

10 ANNEXES

10.1 DECLARATIONS

The following Declarations are hereby attached:

- Declaration of conformity

10.2 DIAGRAMS

The following Diagrams are hereby attached:

- Electric circuit diagram and key;
- Pneumatic circuit diagram;
- Machine exploded view.

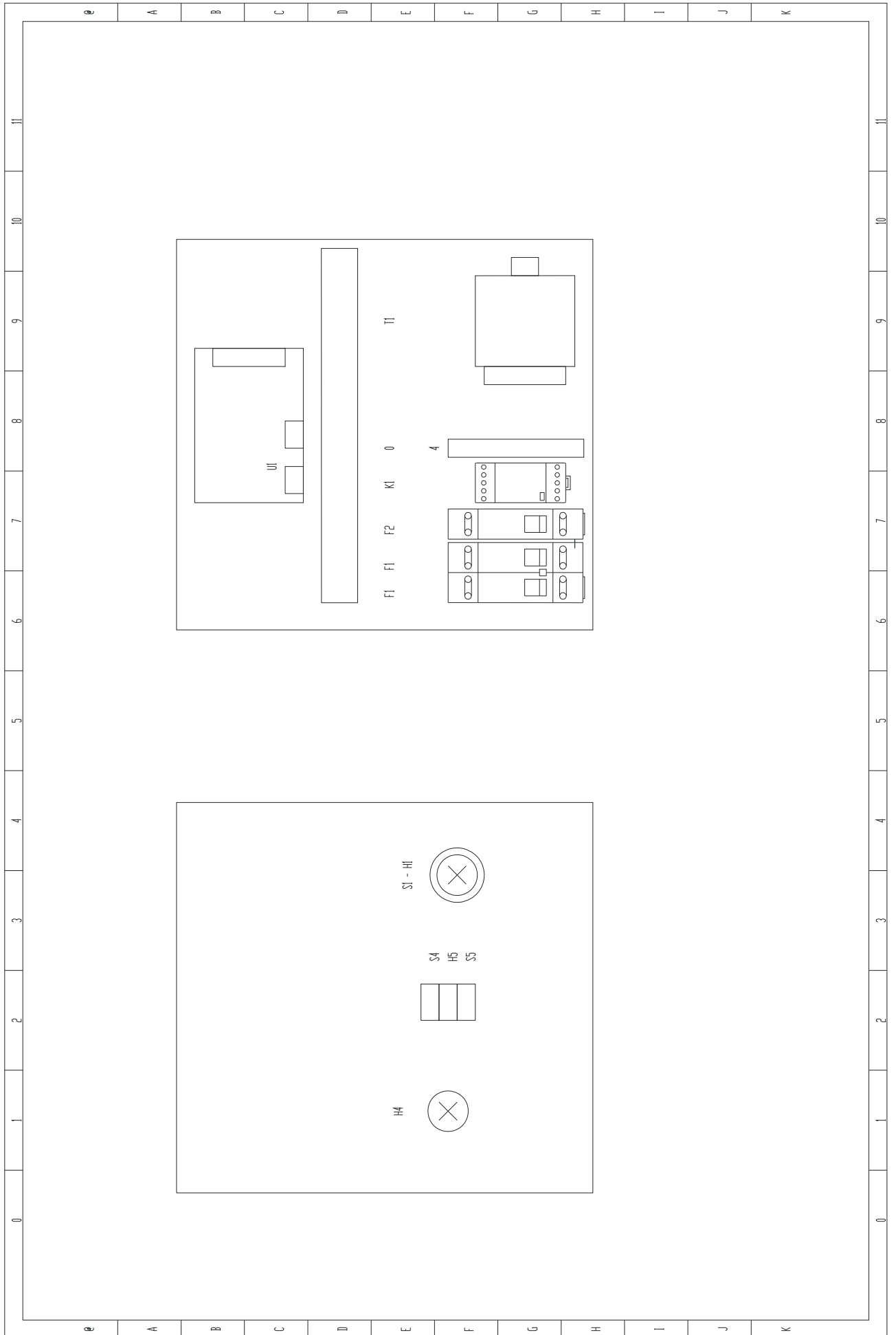

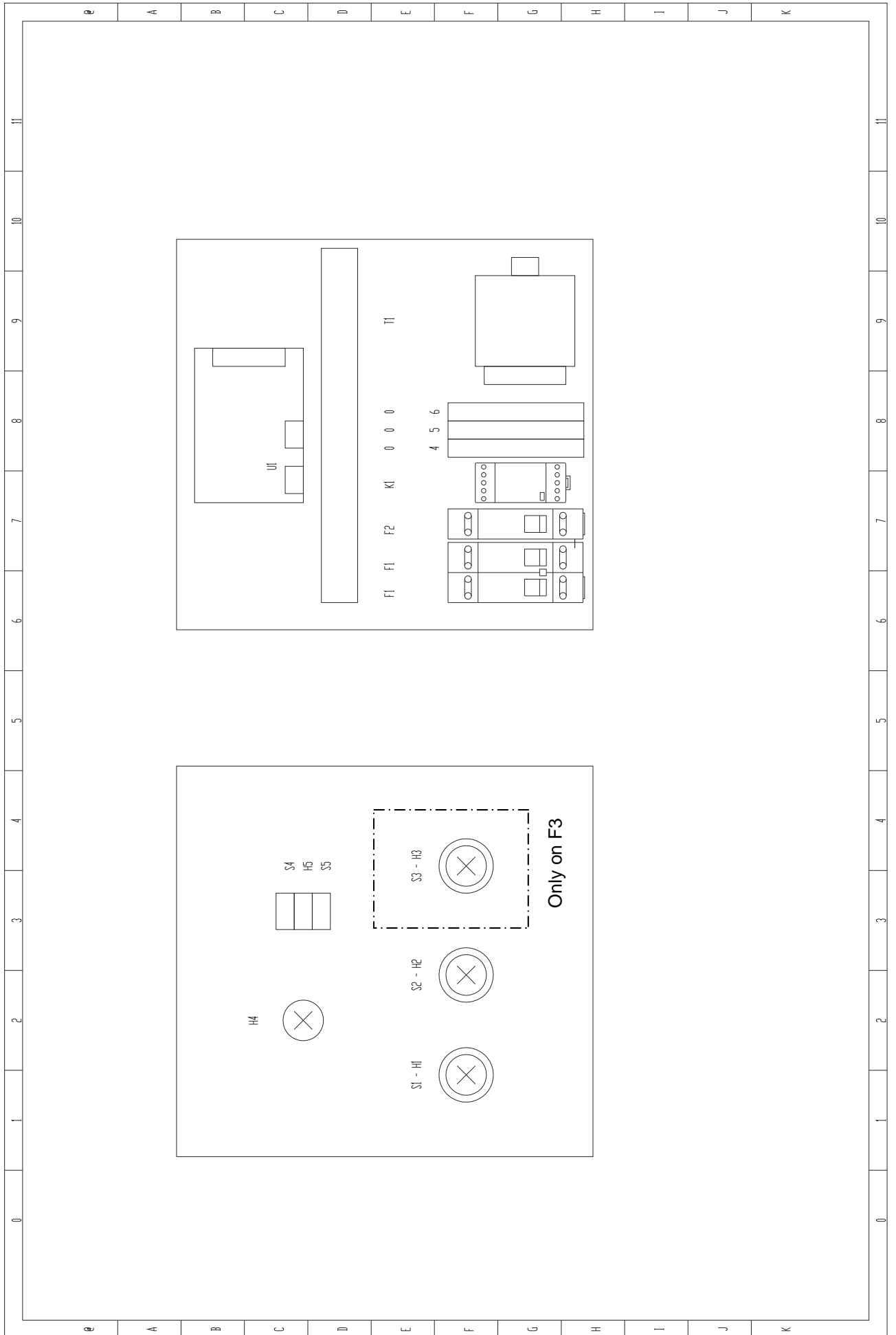



List of components - control panel

ID	Description	Manufacturer - Specs.	Part no.
F1	Primary fuse	Italweber	10x38 0.5A
F2	Secondary fuse	Italweber	10x38 1A
T1	Transformer	Elma 7	50VA 0-230-400/0-24
K1	Auxiliary relay	Omron	G2R2 24V
U1	Timer	CAV	F1: 9142 F2-F3: 9162
S1-H1 S2-H2 S3-H3	Manual cleaning pushbutton	Moller	M22-DL-G
H4	Power supply warning light	Moller	M22-LC-W
S4-H5-S5	Start/stop pushbuttons	Moller	M22-DDL-WS-X0-X10



Pneumatic circuit diagram

F1

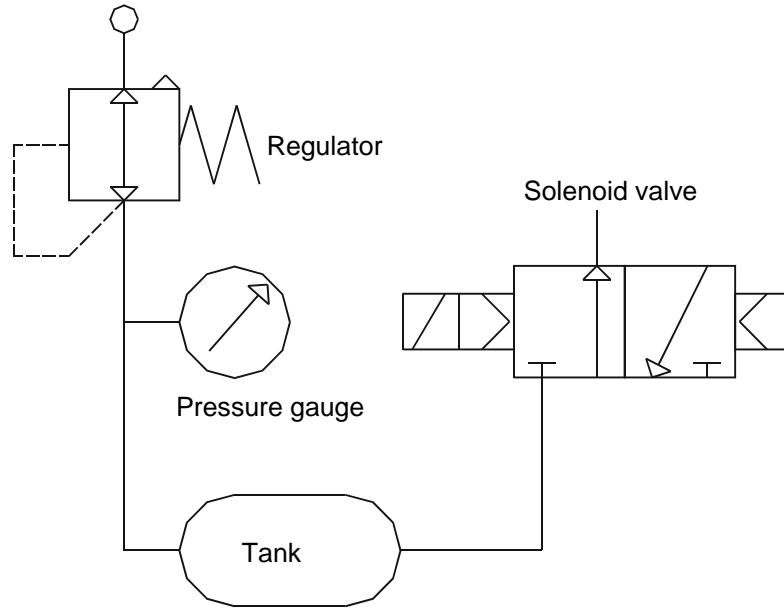

F2-F3

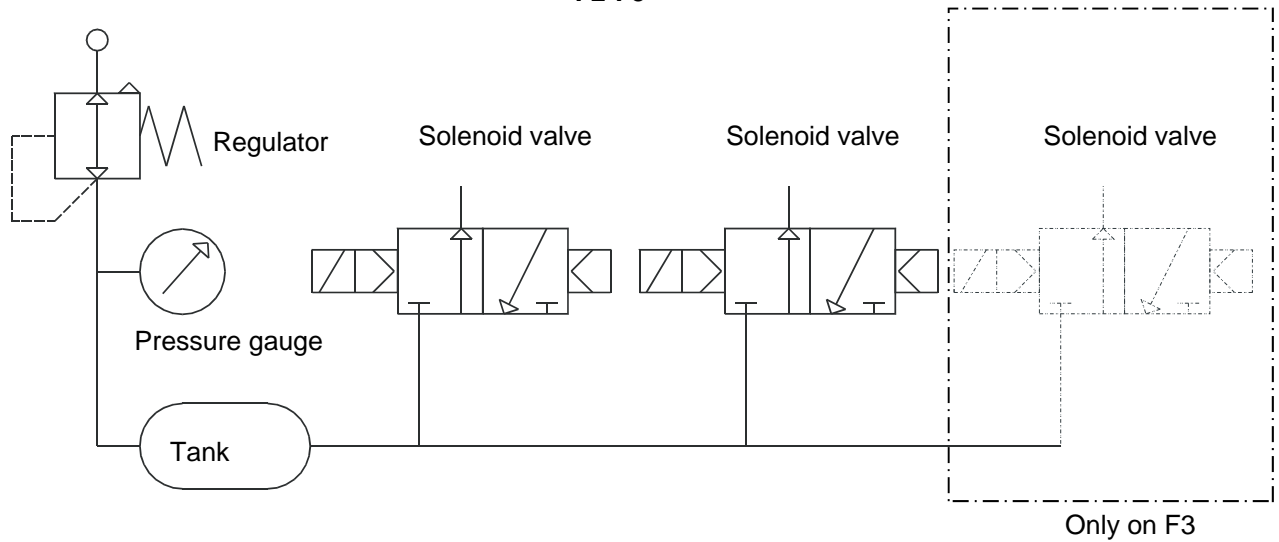

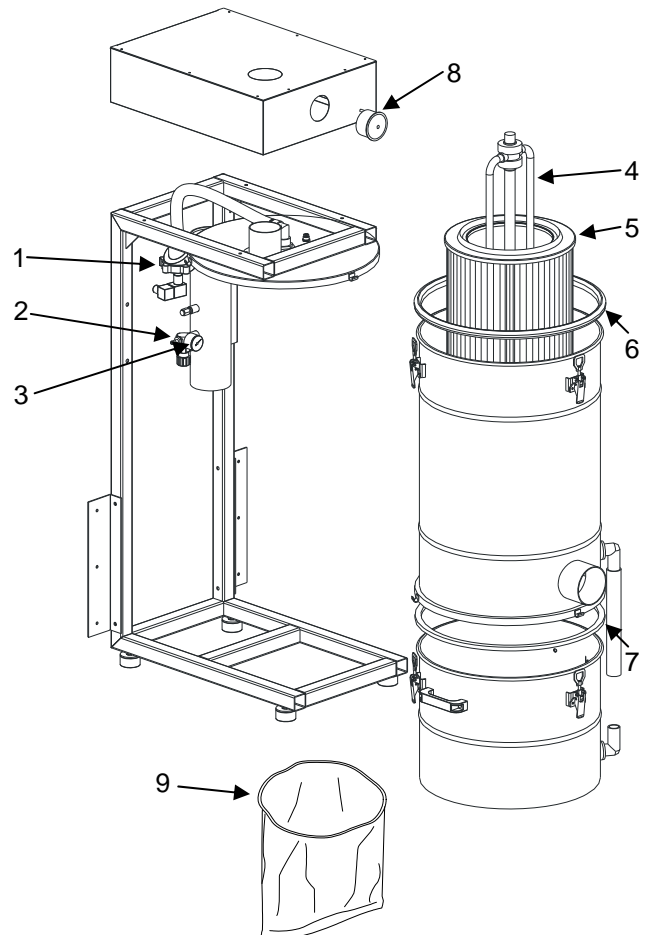
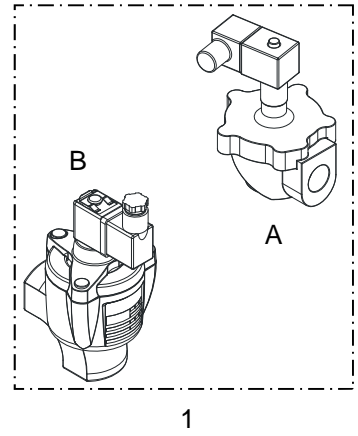
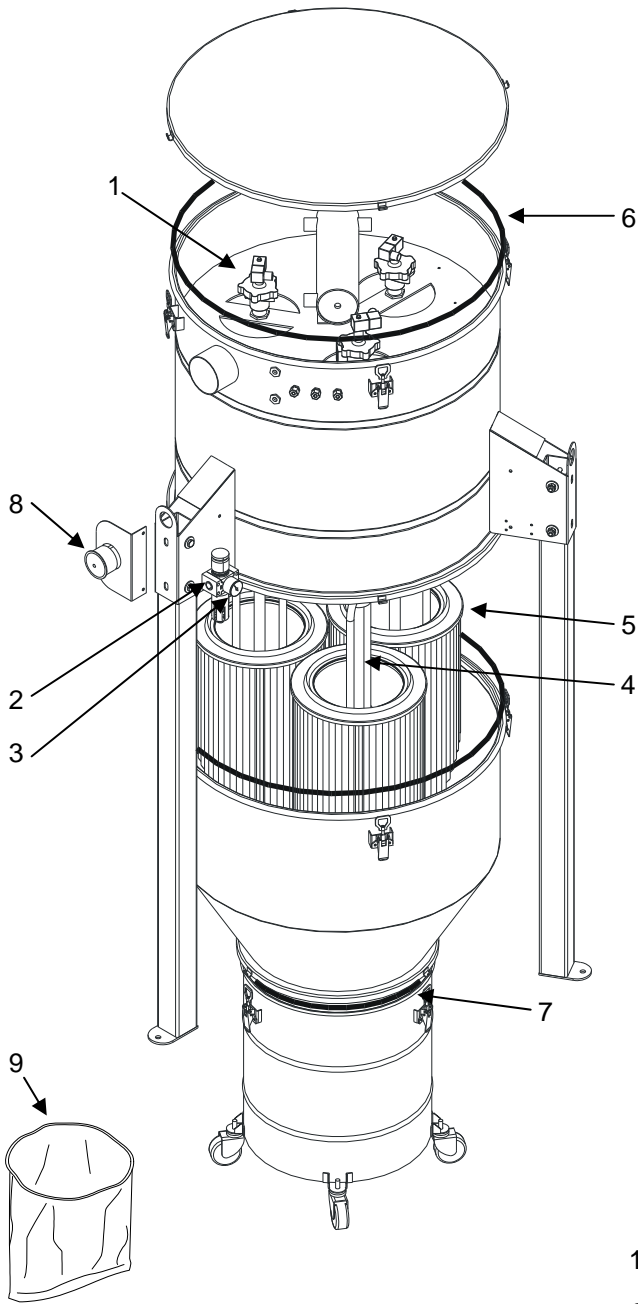

Please see descriptions in Table 8.1 A



THE UNDERSIGNED COMPANY

C.A.V SR.L.

VIA R. VIA MORANDI, 93 - 40060 TOSCANELLA DI DOZZA (BOLOGNA), ITALY
PHONE: +39 0542 673488 - TELEFAX: +39 0542 672065
E-MAIL: SALES@CAVITALY.COM - HTTP://WWW.CAVITALY.COM
M/BO 015576
ITALY

DECLARES, UNDER ITS OWN RESPONSIBILITY, THAT THE MACHINE

MODEL

SERIAL NO.:

CONSTRUCTION DATE

TO WHICH THIS DECLARATION IS REFERRED, COMPLIES WITH THE FOLLOWING DIRECTIVES:

DIRECTIVE 2006/42/EC (MACHINERY DIRECTIVE)

DIRECTIVE 2006/95/EC (LOW VOLTAGE DIRECTIVE)

DIRECTIVE 2004/108/EC (ELECTROMAGNETIC COMPATIBILITY DIRECTIVE)

FURTHERMORE, WE DECLARE THAT THE TECHNICAL DOSSIER HAS BEEN DRAWN UP BY:

LUCA LUCIA
C/O C.A.V. SRL
VIA R. VIA MORANDI, 93 - 40060 TOSCANELLA DI DOZZA (BOLOGNA), ITALY
PHONE: +39 0542 673488 - TELEFAX: +39 0542 672065
E-MAIL: UT@CAVITALY.COM

TOSCANELLA,

TECHNICAL DOSSIER DRAFTER

LUCA LUCIA

LEGAL REPRESENTATIVE

DOMENICO LUCIA



**Please fill in and return this form by Fax
for Warranty registration**

Date:

Machine model:

Serial no.:

Year of manufacture:

To be filled in by the Customer

Company name

Address

Phone no.: Fax no.: E-mail:

Company name of installing firm

.....
.....



C.A.V. srl

Via R. Morandi, 93 - 40060 Toscanella di Dozza (BO)

Tel.: +39 0542 673488 / Fax: +39 0542 672065

www.cavitaly.com - sales@cavitaly.com

www.smaisystem.com - info@smaisystem.com